



GAI-TRONICS®
A HUBBELL COMPANY

Model 709-901

SmartSeries Handset/Speaker Amplifier

TABLE OF CONTENTS

Confidentiality Notice 1

General Information 1

System Requirements and Limitations 1

Features and Functions 2

Description of Major Components 2

 External Components 2

 Internal Components 3

Block Diagram 4

Interfaces 4

Installation 5

Models 707-001-UL/EX and -EX-F07045 5

Models 708-001-UL/EX, -EX-F07048, 7085-001-UL/EX, -EX-F07044, 7085-004-UL/EX and -EX-F07049 5

Models 7085-005-UL/EX and -EX-F07050 6

Operation 6

Handset Operation 6

Optional Features 7

Maintenance 7

Fuses 7

Adjustments 8

 Minimum Level Adjustment 8

 Offset Level Adjustment 9

 VLC Level Adjustment 9

Internal Adjustments 10

 Sidetone Volume and Handset Receiver Volume 10

Troubleshooting 11

How to Diagnose Assembly Faults 12

Replacement Parts 13

Specifications 14



GAI-TRONICS®
A HUBBELL COMPANY

Model 709-901

SmartSeries Handset/Speaker Amplifier

Confidentiality Notice

This manual is provided solely as an operational, installation, and maintenance guide and contains sensitive business and technical information that is confidential and proprietary to GAI-Tronics. GAI-Tronics retains all intellectual property and other rights in or to the information contained herein, and such information may only be used in connection with the operation of your GAI-Tronics product or system. This manual may not be disclosed in any form, in whole or in part, directly or indirectly, to any third party.

General Information

This document discusses installing, operating, and maintaining the Model 709-901 SmartSeries Handset/Speaker Amplifier. It provides the following features:

- Supports one-way page announcements over system speakers
- Serves as an amplifier to broadcast page announcements over the station's speaker
- Supports party-line (two-way) communication with other system users
- Serves as a control interface to optional devices such as the party line End-of-Line Module or the SmartSeries station Remote Terminal Unit (RTU) when installed into a SmartSeries RTU enclosure.

System Requirements and Limitations

The Model 709-901 SmartSeries Handset/Speaker Amplifier is designed to provide an intelligent handset for use on the GAI-Tronics multi-party system cable in either a standard Page/Party® system or an ADVANCE system.

The Model 709-901 SmartSeries Handset/Speaker Amplifier is designed for use only with SmartSeries hazardous area equipment. This equipment includes the following enclosure models:

- | | |
|-----------------------------------|--|
| 707-001-UL/EX; -EX-F07045 | UL Listed SmartSeries Amplifier Enclosures |
| 708-001-UL/EX; -EX-F07048 | UL Listed SmartSeries Single Party Enclosures |
| 7085-001-UL/EX; -EX-F07044 | UL Listed SmartSeries Multi-Party Enclosures |
| 7085-004-UL/EX; -EX-F07049 | UL Listed SmartSeries Multi-Party Enclosures with Alternate Page* |
| 7085-005-UL/EX; -EX-F07050 | UL Listed SmartSeries Multi-Party Enclosures with RTU Control* |

*NOTE: The models with Alternate Page and RTU Control features must be installed in an ADVANCE cabinet system.

The Model 709-901 SmartSeries Handset/Speaker Amplifier contains all of the necessary connectors for use with any of the models listed above. Some connectors will not be used on all models.

Features and Functions

- Monitors and controls the handset and auxiliary connections, if equipped.
- Measures the ambient noise and adjusts the speaker output level accordingly.
- Supervises the local speaker.
- Supports an optional SmartSeries station RTU, which monitors and supervises input and output devices.
- Supports an optional party line End-of-Line Module, which supervises party line 1.
- Transfers data messages and audio on the system cable.

Description of Major Components

This assembly includes external components accessible to the user as well as internal components or subassemblies.

External Components

As shown on the bottom view of Figure 1, the assembly includes a connector for the push-to-page operator, a hookswitch and handset connector, and a connector for the RTU connection. When the handset on the front of the enclosure is lifted from the cradle or replaced in the cradle, a hookswitch (a magnetic reed switch) signals the appropriate status to the microcontroller within the assembly. In the center of the front panel, the GAI-Tronics nameplate conceals the User Level Adjustment control.

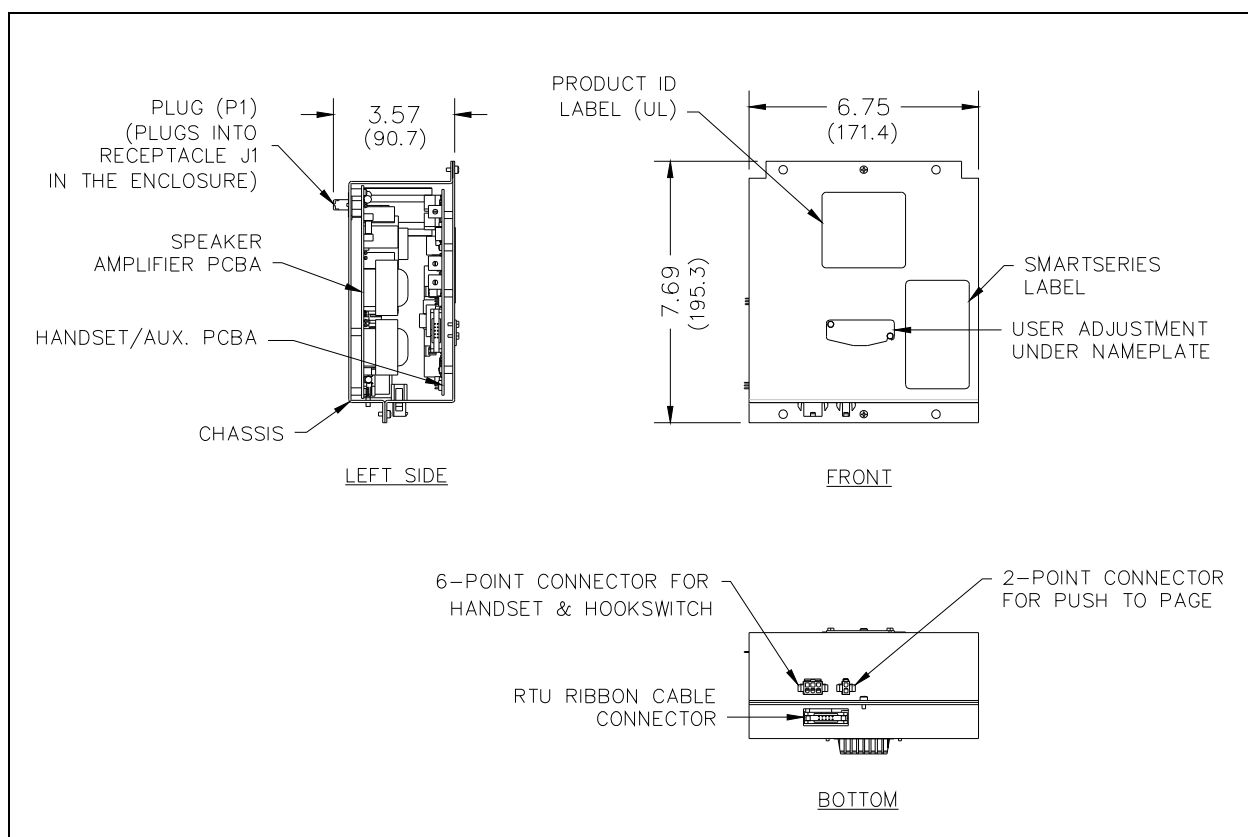

Figure 1. Model 709-901 Outline Drawing

Internal Components

As shown from the side in Figure 2, the assembly contains the following components or subassemblies:

- Chassis
- Front panel affixed to the front of the chassis
- Handset Amp/FSK/ μ P PCBA (printed circuit board assembly) (Ref. 14) affixed to the rear of the front panel
- Speaker Amp/Power Supply PCBA (Ref. 13) affixed to the rear of the chassis, with a plug (P1) at the top, pointing to the rear

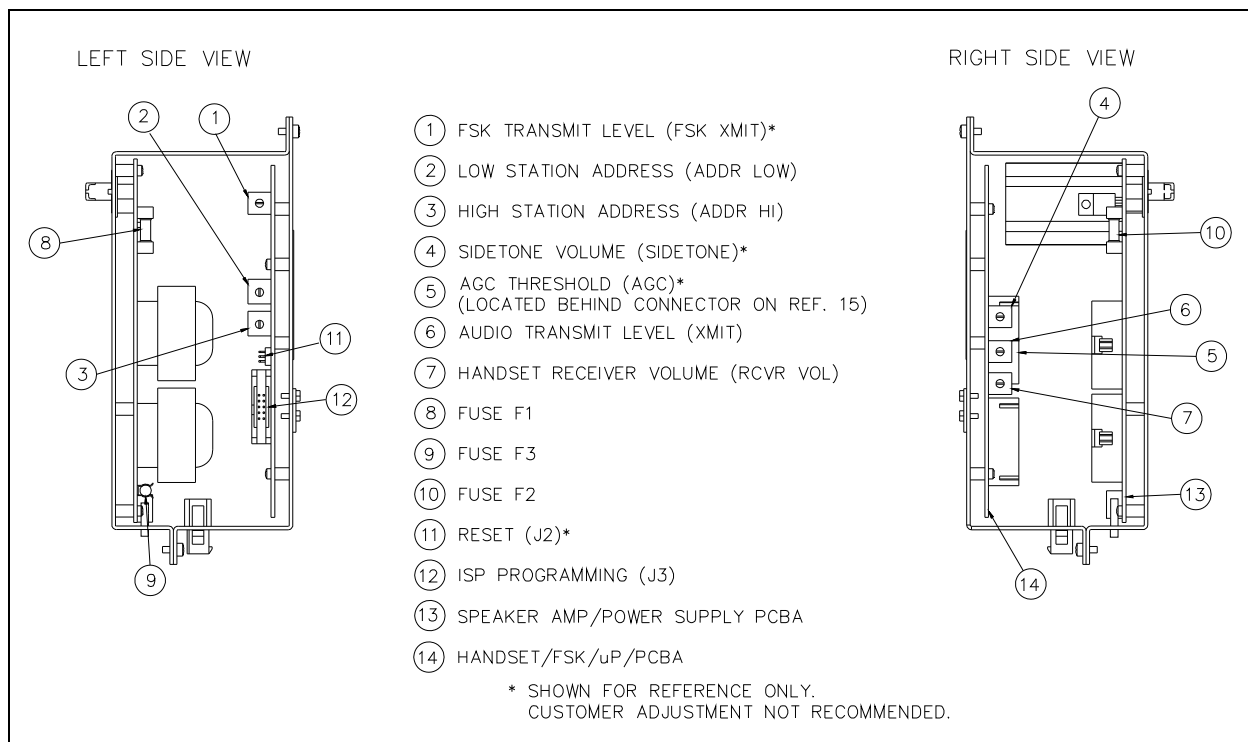

Figure 2. Side View

Block Diagram

The P1 connector on the back of the Speaker Amp/Power Supply PCBA plugs into a socket in an enclosure connected to the system cable, accessing the Page/Party[®] lines and ac power. The Speaker Amp/Power Supply PCBA contains the low voltage power supplies and the speaker amplifier circuitry.

Connector J1A and J1B on the Speaker Amp/Power Supply connects regulated +5 V dc, +/-15 V dc, and V_{RLY} voltages along with control, monitoring, and line signals to the J1A and J1B on the Handset Amp/FSK/μP PCBA. Connector J2 of the Speaker Amp/Power Supply PCBA connects to optional external devices.

The Handset Amp/FSK/μP PCBA has connections to the handset, hookswitch, and push-to-page operator on the front of the hazardous enclosure. The PCBA's terminal connectors E1 to E7 connect to the 2-point and 6-point connectors in the bottom of the amplifier enclosure.

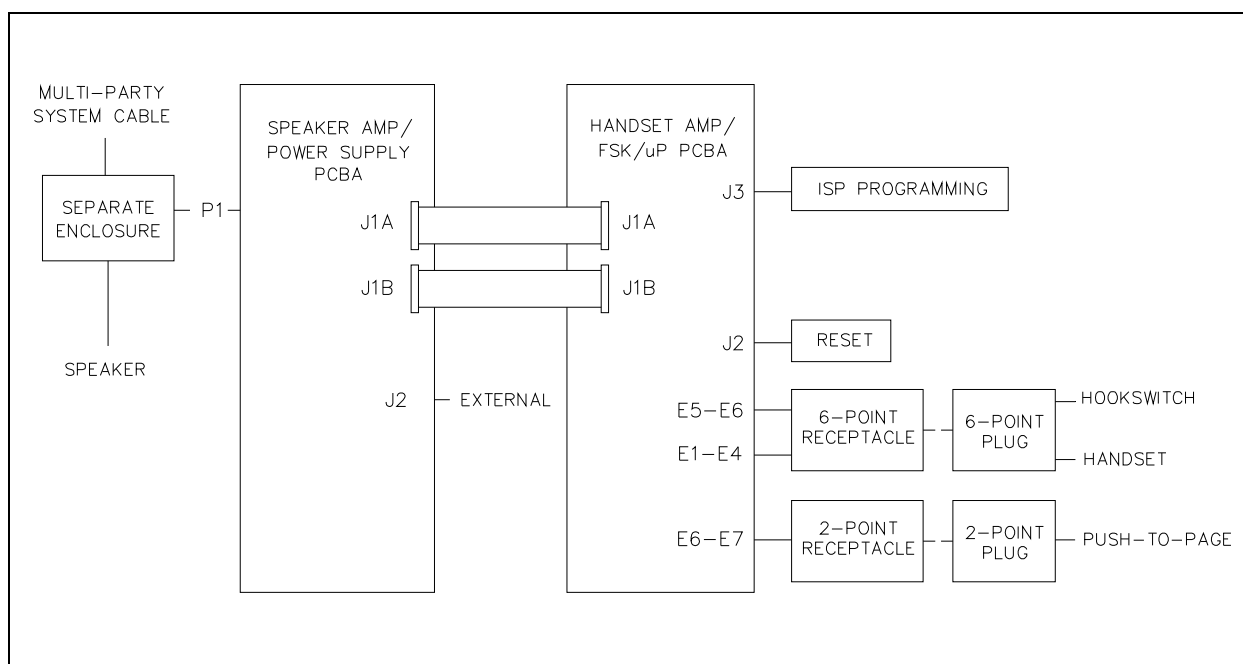

Figure 3. Block Diagram



Interfaces

The assembly interfaces to the system cable, an external loud speaker, and auxiliary devices via P1, a 16-pin connector. All connections to the system cable are made by qualified installation technicians during the system installation.

Direct questions about these connections to the GAI-Tronics Field Service Department at 800-492-1212 inside the USA or 610-777-1374 outside the USA. Other connections on the Speaker Amp/Power Supply PCBA provide quick connect/disconnect of subassemblies.

Connector J2 on the bottom of the Speaker Amp/Power Supply PCBA connects to optional devices such as the SmartSeries Remote Terminal Unit (RTU) installed in specially designed enclosures.

Installation

 **CAUTION**  **Do not install this equipment in hazardous areas other than in an approved enclosure, or areas other than those indicated on the approval listing in the “Specifications” section of this manual. Such installation may cause a safety hazard and consequent injury or property damage.**

 **WARNING**  **Do not disconnect equipment while energized.**

The Model 709-901 SmartSeries Handset/Speaker Amplifier assembly plugs directly into the following GAI-Tronics SmartSeries hazardous area enclosures listed below. Use extra care not to damage the protruding latch wings of connector J2 located on the bottom edge of the amplifier during installation.

707-001-UL/EX; -EX-F07045	UL Listed SmartSeries Amplifier Enclosures
708-001-UL/EX; -EX-F07048	UL Listed SmartSeries Single Party Enclosures
7085-001-UL/EX; -EX-F07044	UL Listed SmartSeries Multi-Party Enclosures
7085-004-UL/EX; -EX-F07049	UL Listed SmartSeries Multi-Party Enclosures with Alternate Page*
7085-005-UL/EX; -EX-F07050	UL Listed SmartSeries Multi-Party Enclosures with RTU Control*

Models 707-001-UL/EX and -EX-F07045

Ensure that the connectors mate securely and then tighten the four screws in the corners of the front panel. Tighten to 10 to 12 in-lb. or 1.13 to 1.36 N-m.

Models 708-001-UL/EX, -EX-F07048, 7085-001-UL/EX, -EX-F07044, 7085-004-UL/EX and -EX-F07049

1. When installing the amplifier in these enclosures, connect the 2-point plug cable from the push-to-page operator to the 2-point receptacle on the bottom of the amplifier chassis.
2. Connect the 6-point plug cable from the hookswitch and handset to the 6-point receptacle on the bottom of the amplifier chassis.
3. Ensure that the connectors mate securely and then tighten the four screws in the corners of the front panel. Tighten to 10 to 12 in-lb. or 1.13 to 1.36 n-m.

Models 7085-005-UL/EX and -EX-F07050

1. When installing the amplifier in this enclosure, connect the 2-point plug cable from the push-to-page operator to the 2-point receptacle on the bottom of the amplifier chassis.
2. Connect the 6-point plug cable from the hookswitch and handset to the 6-point receptacle on the bottom of the amplifier chassis.
3. Connect the 10-conductor keyed ribbon cable to J2 on the bottom of the Speaker Amp/Power Supply PCBA. Be sure that the red line on the edge of the cable lines up with J2-pin 1.
4. Ensure that the connectors mate securely and then tighten the four screws in the corners of the front panel. Tighten to 10 to 12 in-lb. or 1.13 to 1.36 n-m.

Operation

Note regarding the busy tone: A busy tone is heard in the receiver when either of the following occurs:

- a higher priority page is in progress
- a page is attempted within one second of a previous page

Handset Operation

The handset allows the user to make page announcements and conduct party-line conversations.

Page Announcement

To make a page announcement for a party-line conversation, perform the following steps:

1. Lift the handset from the cradle.
2. Select an available party line.
3. Press the push-to-page operator.
4. Make your announcement when the wait tone stops. If the page resource is already in use, you will hear a busy tone. Release the push-to-page operator, and then try again.
5. Release the push-to-page operator.
6. When the party answers conduct your conversation.
7. Replace the handset in the cradle at the end of the conversation.

Party-Line Conversation

To conduct a party-line conversation perform the following steps:

1. For a multi-party enclosure select the appropriate party line.
2. Lift the handset from the cradle.
3. Conduct your conversation.
4. Replace the handset in the cradle when the conversation is finished.

Optional Features

The following features are available as options to the standard configuration of a station used in an ADVANCE system and installed in a standard SmartSeries or a custom enclosure. These features can be configured. Contact the GAI-Tronics Field Service Department at 800-492-1212 inside the USA or 610-777-1374 outside the USA for further information about these features.

- The Selected Page Destination feature allows the manual selection of one of four page destinations.
- The Supervised Input feature allows the monitoring and supervision of one or two initiating device circuits (IDCs), initiating an alarm when the supervised device is activated.
- The Power Relay Module provides a relay contact output, typically to switch power to a visual signaling device, for directed or relay group operation. Supervision of the controlled device's cable can also be enabled.
- The Station Emergency Party Line feature supports annunciation for two party lines.

Maintenance

Regular inspection and a good preventive maintenance program will increase the reliability of your GAI-Tronics station. The GAI-Tronics Field Service Department can formulate a service contract suited to your facility's specific need for preventive maintenance.

If the equipment requires service, contact your Regional Service Center for a return authorization number (RA#). Equipment should be shipped prepaid to GAI-Tronics with the return authorization number and a purchase order number. If the equipment is under warranty, repairs will be made without charge. Please include a written explanation of all defects to assist our technicians in their troubleshooting efforts. Call 800-492-1212 for help in identifying the Regional Service Center closest to you.

 **WARNING**  **Before performing any of the following preventive maintenance steps, remove all power from the station.**

1. Inspect and replace frayed or cracked wiring.
2. Secure/replace loose wires and spade terminals.
3. Remove corrosion from terminals.

Fuses

 **WARNING** 

Do not remove fuses when energized. Replace with the same type and size fuse.

F1 = 0.2A, 250V, 0.25×1.25 inches, Slo-Blo type, UL Listed

F2 = 0.7A, 250V, 0.25×1.25 inches, Slo-Blo type, UL Listed

F3 = 0.15A, 250V, 0.25×1.25 inches, Slo-Blo type, UL Listed

Adjustments

The User Adjustment Control is located beneath the GAI-Tronics nameplate on the front panel. Refer to Figure 1. It is used to make all user adjustments normally required for installation. Loosen the two screws on the GAI-Tronics nameplate and rotate it counterclockwise to access the adjustment hole. Make adjustments by inserting a 1/8-inch flat blade screwdriver through the access hole and into the potentiometer located directly behind the hole.

The User Adjustment Control potentiometer can be used to make three separate adjustments:

- the minimum Speaker Amplifier output level setting
- the Offset Amplifier level (difference between the ambient noise and the amplifier output levels)
- the VLC (volume level control) adjustment
(sets a preset speaker level to override the normal volume control setting).

Minimum Level Adjustment

To set the minimum amplifier output level, insert the 1/8-inch flat blade screwdriver into the User Adjustment Control and set it fully counterclockwise. Listen for a single beep from the speaker indicating the speaker amplifier is in the Minimum Level Adjustment mode. A continuous tone should be heard after the beep tone. (See note below).

This test tone is used as a reference to adjust the speaker amplifier output level to the desired volume. Turn the adjustment pot clockwise for the desired output. The test tone automatically shuts off 5 seconds after the last adjustment. The factory default setting for minimum level is 4.0 watts nominal.

NOTE: If the page line is in use immediately after the beep tone, the page signal should be used to make the minimum level adjustment. If the page line is inactive following the beep tone, a continuous tone is activated to make the minimum level adjustment. After the tone is activated, all page line activity is ignored until completion of the adjustment.

Offset Level Adjustment

The Offset Level allows the output of the SmartVolume™ speaker amplifier to maintain a set difference or “offset” between the ambient noise level and the speaker output level. Turn the User Adjustment Control fully clockwise and listen for the two beep tones indicating that the station is in the Offset Adjustment mode. A continuous tone should be heard from the station speaker. Turn the adjustment pot counterclockwise to the desired output level.

NOTE: If the page line is in use immediately after the two beep tones are heard, the page signal should be used to make the offset level adjustment. If the page line is inactive immediately following the beep tones, a continuous tone is activated to make the minimum level adjustment. After the tone is activated, all page line activity is ignored until completion of the adjustments.

VLC Level Adjustment

When activated, the VLC overrides the normal volume control setting allowing the amplifier level to change to a preset level during an emergency page. The factory default setting for the VLC Level is 10% of maximum power (nominally 1.2 watts).

NOTE: The system must be equipped with a SmartSeries Master Control Unit (MCU) to activate the VLC function.

To adjust the VLC Level:

1. Force the station into the VLC mode by having someone execute a page from a station programmed by the MCU to activate the VLC function.
2. During the page, turn the User Adjustment Control fully counterclockwise, and listen for two beep tones through the page speaker indicating the VLC Adjustment mode has been activated.
3. After the two beep tones, turn the User Adjustment Control to the desired speaker level using the live paging signal to adjust the level. The station automatically exits the VLC Adjustment mode and reverts to normal operation 5 seconds after the last pot adjustment.

Internal Adjustments



To reduce the risk of ignition of hazardous atmospheres, disconnect the equipment from the supply circuit before making any adjustments to the amplifier's handset level.

Although they typically require no adjustments, the following volume levels can be set internally:

Sidetone Volume and Handset Receiver Volume

To make an adjustment it is necessary to remove the assembly from its enclosure and make a temporary connection between the assembly and the enclosure. Refer to Figure 2 for the reference numbers and locations of the adjustment controls. Turn a control clockwise to increase the volume or threshold; turn it counterclockwise to decrease the volume or threshold. Use a small flat-blade screwdriver with an insulated shaft to make adjustments.

To access the controls, perform the following steps:

1. Loosen the four screws that secure the front panel.
2. Remove the assembly from the enclosure. If the enclosure is equipped with an optional EOL Module or SmartSeries station RTU, be careful to not disconnect the ribbon cable on J2 of the Speaker Amp/Power Supply PCBA.
3. Connect the assembly to the enclosure using a Model 10440-002 Maintenance Cable between P1 on the assembly and J1 on the enclosure.
4. Locate and adjust the control on the appropriate PCBA.
5. When you are finished with the adjustment:
 - a) Disconnect the Model 10440-002 Maintenance Cable.
 - b) Insert the assembly into the enclosure.
 - c) Tighten the four screws.

Handset Receiver Volume

Use the control labeled RCVR VOL (Ref. 7, on the Handset/FSK/ μ P PCBA) to adjust to the desired level the handset receiver volume for voice signals from a party line.

Sidetone Volume

The control labeled SIDETONE (Ref. 4, on the Handset/FSK/ μ P PCBA) adjusts the handset/headset sidetone.

Troubleshooting

The following table lists some hints to aid technicians in troubleshooting.

Problem	Possible Solution
Any problem with station performance	<p>Remove the assembly from the enclosure and examine it carefully for obvious faults such as unconnected plugs, loose connections where the wires from the handset and hookswitch connect to the Handset/FSK/μP PCBA, and so on. Determine whether the fault is in the assembly, or in the system, by plugging in a known good spare assembly (set to the same address as the assembly removed). If the fault is in the assembly, remove it for repair.</p> <p>NOTE: When replacing the assembly, perform the following steps:</p> <ol style="list-style-type: none"> 1. Set the address on the new assembly to 0, 3. 2. Plug the assembly into the enclosure. 3. After about 10 seconds, remove the assembly. The station is now set up to request a download of configuration variables from the MCU. 4. Set the unit to the correct address. Set the address to 04 for conventional Page/Party[®] operation or consult the ADVANCE system manual for address assignment information. 5. Plug the assembly back into the enclosure. The station initiates a configuration download request (ADVANCE systems only). The time required to complete the download depends upon system configuration and system activity, but several seconds is typical.
Speaker volume needs adjustment	Use the USER ADJ control to adjust the Minimum Level, Offset Level, or VLC Level (as appropriate). Refer to the “Adjustments” section on page 8.
Incoming handset speech level needs adjustment	Use the RCVR VOL control to adjust the handset receiver volume. Refer to the “Adjustments” section of this document.
Acoustic feedback or speech distortion during page or party operation or The user hears himself when speaking	<ul style="list-style-type: none"> • If the problem affects all stations, the line may not be terminated correctly, may have loose connections, or a short to ground. Line balance connections are critical. • If the problem affects only this assembly, the problem may be with its sidetone setting. Contact the GAI-Tronics Field Service Department.
Feedback during page only	<ul style="list-style-type: none"> • Check within the enclosure for a purple wire on terminal 7: this is the default setting for local speaker mute. If the wire is on terminal 8, then the speaker is unmuted and may be causing feedback. Connect the wire to terminal 7. • An adjacent speaker could be causing feedback. If an adjacent speaker is the source of the feedback, adjust the orientation of the speaker so that it is not aimed directly at the station. As a last resort, enable the mutual muting function of the station. This is done by interconnecting terminal 7 of the two stations with the spare orange wire in the system cable (if this wire is available).
Crosstalk	Likely to be external to the assembly and related to system cable faults.

How to Diagnose Assembly Faults

When the assembly is in an ADVANCE system that includes a vacuum fluorescent display (VFD), faults may be automatically detected, transmitted to the MCU in data messages, and displayed or printed. Fault messages and possible solutions for their causes are described in the table below.

Fault Message	Cause and Effect	Possible Solution
Watch-Dog timer Processor has reset x d times (Where x is the decimal number of times the watchdog timer has reset the processor.)	<p>Cause—The watchdog timer has forced the processor to reset. This occurs when the reset pins (J2) on the Handset/FSK/μP PCBA are temporarily shorted or when the watchdog timer does not receive regular status pulses from U4 on the Handset/FSK/μP PCBA.</p> <p>Effect—The processor maintains a count of the number of resets. If the station is powered down, the count restarts at zero. The station still amplifies incoming pages. For the fourth and subsequent resets, the count is zero.</p>	<ul style="list-style-type: none"> • Verify that the reset pins 2 and 3 (J2) on the Handset/FSK/μP PCBA are not shorted. • Replace the Handset/FSK/μP PCBA.
Stuck Contact on Polled Device Paging Pressbar Depressed	<p>Cause—The station has been in page mode longer than the configured page limit.</p> <p>Effect—Station page is cut off. When the pressbar is released, a restore message is sent to the MCU. The station then resumes normal operation.</p>	<ul style="list-style-type: none"> • Verify that neither the handset pressbar nor the headset page switch is stuck. • Replace the Handset/FSK/μP PCBA. • Replace the Speaker Amp/Power Supply PCBA.
Stuck Contact on Polled Device Handset Off-hook	<p>Cause—The station has been in the off-hook state longer than the configured time limit.</p> <p>Effect—Station handset/headset operation is cut off. When the station is returned to the on-hook state, a restore message is sent to the MCU. The station then resumes normal operation.</p>	<ul style="list-style-type: none"> • Verify that neither the handset is off-hook nor the headset is connected. • Replace the Handset/FSK/μP PCBA, or cradle. • Replace the Speaker Amp/Power Supply PCBA.
Supervised Audio Path Handset	<p>Cause—The station failed its internal health check of the Handset/FSK/μP PCBA.</p> <p>Effect—The station disables the handset amplifier health-check function after the first failure.</p>	<ul style="list-style-type: none"> • Replace the Handset/FSK/μP PCBA. • Replace the Speaker Amp/Power Supply PCBA.
Supervised Audio Path Page Amp	<p>Cause—The station failed its internal speaker amplifier health check.</p> <p>Effect—The station disables the speaker amplifier health-check function after the first failure.</p>	Replace the Speaker Amp/Power Supply PCBA.

Fault Message	Cause and Effect	Possible Solution
Supervised Audio Path Speaker Voice Coil	<p>Cause—The station is detecting no ambient noise at the speaker or is detecting an ambient noise lower than the configured failure threshold. This may occur if there is a fault in the speaker wire or a fault at the voice coil. This also may occur if the ambient noise at the speaker is too low, as is the case in a quiet room.</p> <p>Effect—The station continues measuring speaker ambient noise. When acceptable noise levels are subsequently measured, a restore message is sent to the MCU.</p>	<ul style="list-style-type: none"> • Verify that the speaker wire is connected and intact. • Verify that the voice coil is connected and intact. • Replace the Speaker Amp/Power Supply PCBA. • Replace Handset/FSK/μP PCBA.
Polled device	<p>Cause—This message is output by the MCU when it loses communication with the station. This may occur if there is a fault in the page line, if the station is powered-down, or if there is some fatal malfunction within the station.</p> <p>Effect—The MCU continues to attempt communication with the station. When communication is resumed, a restore message is sent to the MCU.</p>	<ul style="list-style-type: none"> • Verify that the page line is connected and intact. • Verify that the station is installed correctly. • Replace the Handset/FSK/μP PCBA.
Polled End-of-line device	<p>Cause—This message is the same as the “Polled device” fault, except that the affected station has been defined as an end-of-line station in the MCU configuration.</p> <p>Effect—When this fault occurs, the red EOL FLT LED on the PPI bezel lights. When communication is resumed, the LED extinguishes and a restore message is sent to the MCU.</p>	<ul style="list-style-type: none"> • Verify that the page line is connected and intact. • Verify that the station is installed correctly. • Replace the station assembly.

Replacement Parts

Contact GAI-Tronics for replacement part information.

Specifications

Electrical

Supply voltage 90 to 140 V ac (120 V ac nominal), 50/60 Hz

Power consumed @ nominal ac Zero/maximum signal (12 watts): 15 VA, 9 watts/59 VA, 32 watts

Speaker Amplifier

Output 12 watts minimum, with nominal supply voltage

Frequency response..... 350 to 6,500 Hz, +0/-3 dB, ref. to 1 kHz

Distortion 1% maximum THD @ 1 kHz, 12 watts

SmartVolume™

Monitor range (low gain) 62 to 100 dB SPL

Offset (above ambient) User Level Adjustment 0 to 48 dB

Minimum User Level Adjustment Off; 85 to 125 dB SPL

Handset Amplifier

Output 1.5 V_{RMS} nominal into 33-ohm load

Frequency response with 5 mV_{RMS} input (AGC on)..... 350 to 6,500 Hz, +0/-3 dB ref. to 1 kHz

Distortion 1.5% maximum THD @ 1 kHz

Mechanical

Dimensions 7.69 H × 6.75 W × 3.57 D inches (195.3 × 171.4 × 90.7 mm), overall

Environmental

Temperature range -22° F to +158° F (-30° C to +70° C), operating and storage

Humidity 95%, non-condensing

Approvals

NRTL listed Class I, Div. 1, Groups B, C, D;
(USA and Canada) Class II, Div. 1, Groups F, G;

Class III, Div. 1

when used with listed Model 7085-004-UL, 708-001-UL, 7085-001-UL
7085-005-UL, or 707-001-UL Enclosure

CE Mark

Warranty

Equipment. GAI-Tronics warrants for a period of one (1) year from the date of shipment, that any GAI-Tronics equipment supplied hereunder shall be free of defects in material and workmanship, shall comply with the then-current product specifications and product literature, and if applicable, shall be fit for the purpose specified in the agreed-upon quotation or proposal document. If (a) Seller's goods prove to be defective in workmanship and/or material under normal and proper usage, or unfit for the purpose specified and agreed upon, and (b) Buyer's claim is made within the warranty period set forth above, Buyer may return such goods to GAI-Tronics' nearest depot repair facility, freight prepaid, at which time they will be repaired or replaced, at Seller's option, without charge to Buyer. Repair or replacement shall be Buyer's sole and exclusive remedy. The warranty period on any repaired or replacement equipment shall be the greater of the ninety (90) day repair warranty or one (1) year from the date the original equipment was shipped. In no event shall GAI-Tronics warranty obligations with respect to equipment exceed 100% of the total cost of the equipment supplied hereunder. Buyer may also be entitled to the manufacturer's warranty on any third-party goods supplied by GAI-Tronics hereunder. The applicability of any such third-party warranty will be determined by GAI-Tronics.

Services. Any services GAI-Tronics provides hereunder, whether directly or through subcontractors, shall be performed in accordance with the standard of care with which such services are normally provided in the industry. If the services fail to meet the applicable industry standard, GAI-Tronics will re-perform such services at no cost to buyer to correct said deficiency to Company's satisfaction provided any and all issues are identified prior to the demobilization of the Contractor's personnel from the work site. Re-performance of services shall be Buyer's sole and exclusive remedy, and in no event shall GAI-Tronics warranty obligations with respect to services exceed 100% of the total cost of the services provided hereunder.

Warranty Periods. Every claim by Buyer alleging a defect in the goods and/or services provided hereunder shall be deemed waived unless such claim is made in writing within the applicable warranty periods as set forth above. Provided, however, that if the defect complained of is latent and not discoverable within the above warranty periods, every claim arising on account of such latent defect shall be deemed waived unless it is made in writing within a reasonable time after such latent defect is or should have been discovered by Buyer.

Limitations / Exclusions. The warranties herein shall not apply to, and GAI-Tronics shall not be responsible for, any damage to the goods or failure of the services supplied hereunder, to the extent caused by Buyer's neglect, failure to follow operational and maintenance procedures provided with the equipment, or the use of technicians not specifically authorized by GAI-Tronics to maintain or service the equipment. **THE WARRANTIES AND REMEDIES CONTAINED HEREIN ARE IN LIEU OF AND EXCLUDE ALL OTHER WARRANTIES AND REMEDIES, WHETHER EXPRESS OR IMPLIED BY OPERATION OF LAW OR OTHERWISE, INCLUDING ANY WARRANTIES OF MERCHANTABILITY OR FITNESS FOR A PARTICULAR PURPOSE.**

Return Policy

If the equipment requires service, contact your Regional Service Center for a return authorization number (RA#). Equipment should be shipped prepaid to GAI-Tronics with a return authorization number and a purchase order number. If the equipment is under warranty, repairs or a replacement will be made in accordance with the warranty policy set forth above. Please include a written explanation of all defects to assist our technicians in their troubleshooting efforts.

Call 800-492-1212 (inside the USA) or 610-777-1374 (outside the USA) for help identifying the Regional Service Center closest to you.